



EVR 6

Environmental Floodlight

The EVR 6 400W under canopy luminaire employs the ELSCO Seal System offering a lighting solution which is far superior to others currently on the market. By sealing the door and keeping out the bugs and dirt, light levels are maintained for longer, reducing maintenance and running costs and improving amenity. The EVR 6 is ideal for: service stations, gyms, carparks.

EVR 6 400W

SPECIFICATIONS:

| | |
|---------------------|---|
| Dimensions | 633 x 633 x 180 mm |
| Weight | 15kg |
| Finish | Powdercoated white (standard) |
| Lamp | 400W MH (standard) (HPS & MV available on request) |
| Lampholder | Porcelain E40 spring-loaded centre contact |
| Ballast | Reactor/ignitor |
| Part Numbers | EL103015(MH) EL103025(HPS) |

FEATURES

| | |
|---------------------|---|
| Control Gear | <ul style="list-style-type: none"> • Pre-wired and mounted on single tray • Fully accessible with front lens open • Integral |
| Reflector | <ul style="list-style-type: none"> • Symetrical spectral reflector |
| Gasket | <ul style="list-style-type: none"> • Twin vinyl-covered foam gaskets provide complete seal between lens frame and luminaire body |
| Lens | <ul style="list-style-type: none"> • Anodised extruded aluminium frame with reinforced corners incorporating pyramid drop acrylic lens • Securely fastened and silicon sealed into frame • Lens frame is hinged on one side of fixture body with stainless steel fixings |
| Housing | <ul style="list-style-type: none"> • Aluminium • Completely sealed for protection from all weather conditions • Surface mounted |

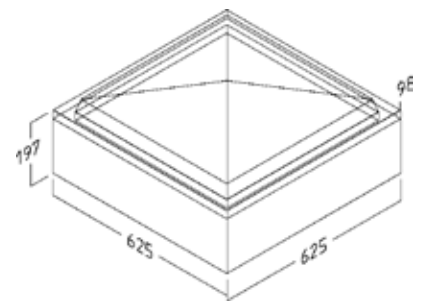

Photometrics

- Horizontal
- Vertical

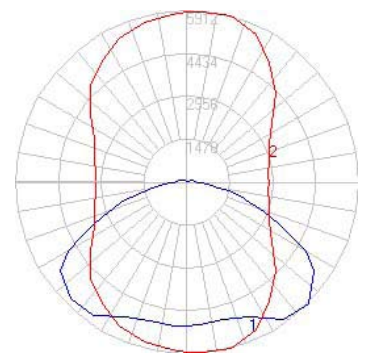

Please contact:

Aglo Systems, 9 Jarrah Drive, Braeside VIC 3195
 Phone: 03 9580 2611 Fax: 03 9580 3144 Email: sales@aglosystems.com.au
www.elscolighting.com.au

Aglo Systems Guarantee:

All bodywork guaranteed for 5 years. Control gear guaranteed for 12 months.