



# EVR 4

## Low Level Environmental Luminaire

The EVR 4 is an ideal perimeter light - designed to provide effective illumination for car parks, walkways, parks, industrial centres, shopping centres etc. with reduced glare and light spill at a low mounting height (6m-10m). The standard lamp is a 400W metal halide (high pressure sodium available on request) which provides high performance, long life and high lumen output.

### EVR4 400W MH

#### SPECIFICATIONS:

<b>Dimensions</b>	615 x 480 x 286 mm
<b>Weight</b>	17Kg
<b>Finish</b>	Powdercoated satin black (standard)
<b>Lamp</b>	400W MH (standard) (HPS available on request)
<b>Lampholder</b>	Porcelain E40 spring-loaded centre contact
<b>Ballast</b>	Reactor/ignitor
<b>Part Numbers</b>	EL102025 (MH) EL102125 (HPS)

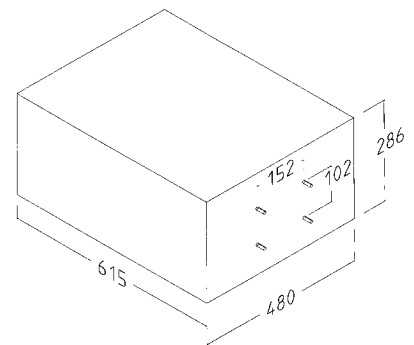

#### FEATURES

<b>Control Gear</b>	Pre-wired and mounted on single tray. Fully accessible with front lens open. Concealed behind silk-screened section of lens. Integral.
<b>Reflector</b>	Sharp cut-off, forward throw high purity polished and anodised aluminium reflector.
<b>Gasket</b>	Twin vinyl-covered foam gaskets provide complete seal between glass frame and fixture body.
<b>Lens</b>	Anodised extruded aluminium frame with reinforced corners incorporates 4mm toughened glass lens, securely fastened and silicon sealed into frame. Lens frame is hinged on one side of fixture body with stainless steel fixings.
<b>Housing</b>	Aluminium. Completely sealed for protection from all weather conditions. Mounted via four stainless steel bolts at rear of fixture. Internal support frame to protect against body distortion.

#### Photometrics

■ Horizontal  
■ Vertical

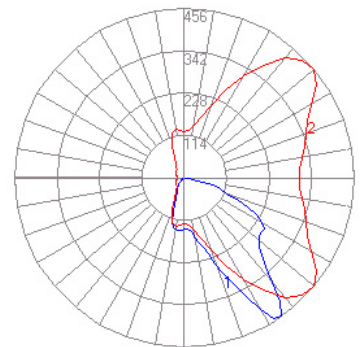

#### Please contact:

**Aglo Systems**, 9 Jarrah Drive, Braeside VIC 3195  
 Phone: 03 9580 2611 Fax: 03 9580 3144 Email: sales@aglosystems.com.au  
[www.elscolighting.com.au](http://www.elscolighting.com.au)

#### Aglo Systems Guarantee:

All bodywork guaranteed for 5 years. Control gear guaranteed for 12 months.

